

4K UHD & Multi-HD Encoder and Bonded Cellular Transmitter

The Haivision Pro460 is our latest generation mobile video encoder and transmitter designed for live broadcasters and news gathering professionals looking to contribute high-quality video from any location. Multi-camera HD and pristine 4K UHD encoding, including in HDR are combined with reliable low latency mobile transmission capabilities in this 5G compliant solution.

With its compact form factor, the Pro460 includes the latest generation of hardware accelerated H.265/HEVC encoding for premium video quality with optimized data usage and end-to-end latency as low as 200ms. The widely adopted H.264/AVC codec is also supported for interoperability with all types of video destinations. Our innovative design is suited for a variety of broadcast contribution workflows from single camera HD sources for news, to multi-camera HD (up to 4) for live sports, and 4K UHD content for premium events coverage.

The Pro460 offers a full set of advanced features for live broadcast contribution and remote production. This includes perfect video synchronization and lip sync from multiple cameras and across all video streams to guarantee seamless camera switching and efficient video editing at the receiving end, in the remote production studio. The Pro460 can connect to network-based devices such as PTZ cameras and tally lights for remote control by a Haivision StreamHub receiver, even during live transmissions. The Pro460 also supports low latency and high-quality video returns including teleprompting information or studio feeds. A bi-directional audio intercom (IFB) is also available for real-time communication between field and production staff.

The Pro460 embeds six globally compliant 3G/4G/5G cellular modems with our high efficiency and patented antennas. Video transmissions can also be sent over other types of IP network including WiFi, Ka or Ku band satellite, an IP leased line and the public internet. Our Emmy® awarded SST Technology (Safe Stream Transport) offers advanced and dynamic network aggregation, adaptive packet retransmission (ARQ) and forward error correction (FEC) to maximize network throughput and optimize the quality of service.

Available in a compact ruggedized enclosure, the Pro460 offers standard V-Mount or Gold-Mount plates for direct mounting on professional cameras or can be used with the included specially designed backpack.



Simple

The Pro460 is extremely user-friendly and features an intuitive touch-screen user interface enabling camera operators to begin broadcasting live video with just 2 taps.



Versatile

The Pro460 is a versatile all-in-one solution for mobile video contribution and remote production. Encode and transmit a single 4K UHD source or four simultaneous HD sources with up to 10-bit pixel depths, 4:2:2 chroma subsampling, and in HDR.



High Performance

By implementing an ultra-low latency H.265/HEVC hardware encoder in a compact design enclosure, the Pro460 enables video professionals to provide seamless and pristine video for news and events coverage.



Any Network

Leveraging the Emmy® award winning SST and SRT protocols, the Pro460 can reliably transmit high-quality broadcast contribution video over bonded cellular and IP networks with fluctuating conditions.

Main Functions

Premium Live Video up to 4K UHD The Haivision Pro460 offers the highest-quality video performance and the latest generation of HEVC encoding technology for pristine HD and UHD video transmission over mobile networks including 5G. Built on the two-time award-winning SST cellular bonding technology, the Pro460 can transmit live video with bitrates up to 80Mbps for high-quality broadcast contribution.

Multi-camera Remote Production Bring your remote production and REMI workflows to the next level with four frame-synced HD feeds and simultaneous remote control of IP-based equipment including PTZ cameras. Thanks to high bandwidth and low-latency video transmission over 4G and 5G networks supported by its 6 internal modems and antennas, the Pro460 enables multi-camera remote production from anywhere.

IFB & Video Return Ensure two-way audio communication between the producer, camera operator & on-air talent thanks to a seamless and robust intercom system. The Pro460 can also receive a high-quality HD feed from the production studio during a live broadcast or in standby mode. With sub-second latency streaming, Pro460 return feeds can be used for watching on-air programs, teleprompting information or confidence monitoring from the field.

Record & Progressive Forward Record UHD/HD broadcast-grade quality video on an SD card, and optimize your file forwarding time by with progressive uploads while the live recording is still in progress. The Pro460's advanced recording and file forwarding enables fast and error-free video delivery over any mobile or IP network.

VIDEO

Standards
 UHD: 2160p60/59.94/50/30/29.97/25
 HD: 1080p60/59.94/50/30/29.97/ 25
 1080i60/59.94/50
 720p60/59.94/50

Density
 Single UHD/HD
 Quadruple HD

Encoding
 H.265/HEVC 4:2:0/4:2:2 8/10-bit
 H.264/AVC 4:2:0, 8-bit
 Dynamic resolution adjustment
 High Dynamic Range (HLG & PQ)

Bitrates
 2 Mbps to 80 Mbps for UHD
 300 Kbps to 20 Mbps for HD
 Constant Bitrate (CBR)
 Variable Bitrate (VBR)

Inputs
 SDI

AUDIO

Encoding
 AAC-LC

Bitrates
 32 Kbps to 256 Kbps

Mode
 Mono, Stereo

Density
 Up to 4 Mono or up to 4 Stereo

Inputs
 Embedded over SDI

NETWORK CONNECTIONS

Cellular
 6 x 3G/4G/5G world-wide compliant modems
 - Sub 6GHz bands
 - SA (Stand Alone) and NSA (Non Stand Alone)
 - Internal high efficiency antennas

Ethernet
 2 x Gigabit Ethernet ports
 - LAN, WAN
 - portable satellite (Ka & Ku Band)

Wi-Fi
 Dual band Wi-Fi modem 802.11a/b/g/n/ac (2.4GHz and 5 GHz)
 - Client & Hot Spot modes
 - High-efficiency embedded antenna

Transport Protocol
 SST over Cellular/Ethernet/WiFi (bonding)
 SRT over Ethernet

ADVANCED FEATURES

Dual encoding for simultaneous Live & Record (single HD mode)
 Sub second glass-to-glass latency (down to 200 ms in single encoder mode and down to 500 ms in multi-encoder mode)
 Video and Audio level preview
 Intercom/IFB
 Video return from Studio (full HD, sub-second latency)
 Automatic Live Start
 Networks Links priorities (user configurable)
 Data Bridge for switching the device as mobile router
 Simultaneous Live and IP traffic (for remote camera control)
 Geolocation (GPS)
 SMPTE-12M timecode passthrough

INTERFACES

1 x 12G/3G-SDI input and 3 x 3G-SDI inputs (BNC)
 1 x 12G-SDI output (BNC)
 1 x HDMI 1.4 output
 1 x GenLock input (BNC)
 2 x RJ-45 Ethernet
 2 x USB 3.0 (type-A), 1 x USB 3.0 (type-C)
 6 x micro SIM slots
 1 x mini jack for IFB/intercom headset
 1 x micro SD card slot

CONTROL & MONITORING

Embedded touch screen
 Web UI from any browser
 From Haivision StreamHub transceiver
 From Haivision Manager

POWER

Power Supply
 DC input 18V
 External battery with V-mount or Gold-mount plates

Consumption
 4 hours with battery (90 Wh)

PHYSICAL

Dimensions (W x H x D)
 26,6 cm x 8,4 cm x 12,5 cm
 (10.47" x 3.30" x 4.92")

Weight
 1.5 Kg / 3.3 lbs

Operating Temperature
 0°C to 45°C (32°F to 113°F)

System Overview

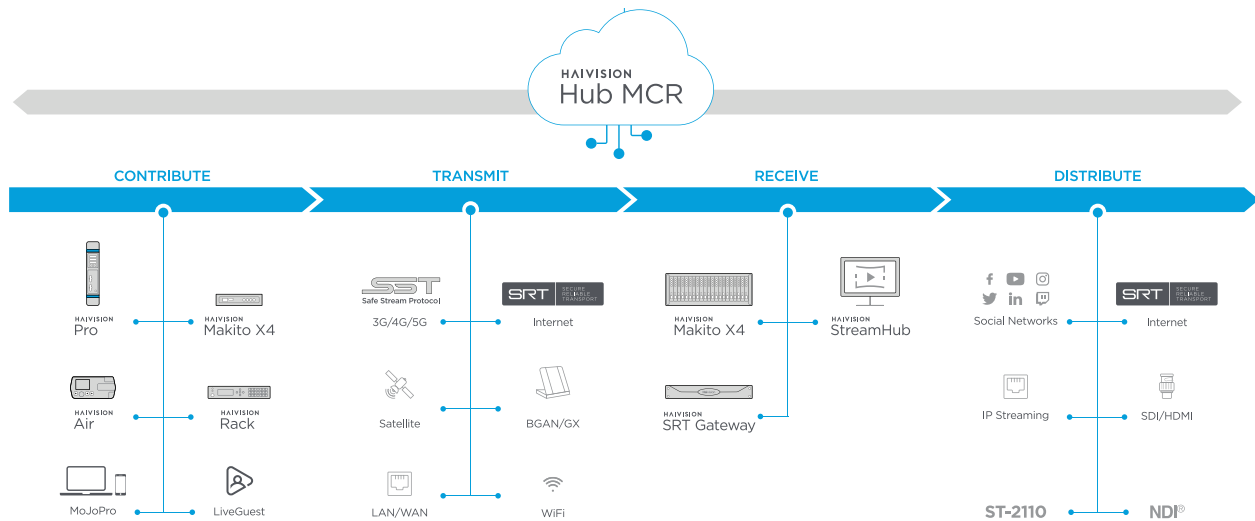

Ultra-Compact Video Encoder and Bonded Cellular Transmitter

Haivision Air is a range of mobile video transmitters for broadcasting live news, sports and other types of events from anywhere over bonded cellular and IP networks. Designed to be extremely compact and portable, the Haivision Air transmitter encodes high quality video from SDI and HDMI sources, to H.265/HEVC or H.264/AVC at very low latency. Real-time video streams can then be transmitted with SST (Safe Streams Transport) over a bonded pair of 3G/4G or 5G modems, depending on the model. Haivision Air can also transmit live video over the public internet the SRT protocol with Ethernet or WiFi connectivity.

Other advanced features include the ability to simultaneously record live broadcasts which can be forwarded on as a progressive file, automatically sent as a clip once a recording has finished or stored on a local SD card. Haivision Air operators also benefit from receiving low latency return feeds to an external display and bidirectional IFB audio for real-time interaction with the production team. All of these features and more can be easily accessed from the Haivision Air's intuitive front panel display.



Simple

Haivision Air features an intuitive user interface enabling camera operators to broadcast live in seconds.



Versatile

Compact, lightweight, and featuring a rechargeable battery, the Haivision Air is the ideal travel companion for camera operators and mobile journalists who need to go live at any time.



High Performance

Encode, record, and transmit HD video in HEVC or H.264 at very low latency for reliable and high-quality sports, news, and live event coverage.



Any Network

Haivision Air supports the Emmy® award winning SST (Safe Stream Transport) and SRT (Secure Reliable Transport) protocols for reliable video streaming over bonded cellular and IP networks.

| | AIR320-5G | AIR220-5G | AIR220 | AIR200 |
|--|-----------|-----------|--------|--------|
| H.265/HEVC encoder | • | | | |
| H.264/AVC encoder | • | • | • | • |
| Embedded cellular modems | 5G/4G/3G | 5G/4G/3G | 4G/3G | |
| 4 extension links (Wi-Fi, Ethernet, USB) | • | • | • | • |

Main Functions

Live & Auto-Record Broadcast premium quality video live over bonded cellular and IP networks: 5G/4G/3G, Ethernet, Wi-Fi, and satellite Ka and Ku Bands. Live broadcasts can be simultaneously recorded on an SD card.

Rec & Progressive Fwd For non-live applications, video files can be shared with production as they are being recorded or automatically forwarded once a recording is complete.

Data Bridge Leverage SST's bidirectional data support by using a Haivision Air as a mobile router for establishing a high-speed internet connection from anywhere.

Video Return and IFB Ensure communication between the producer, camera operator & on-air talent with high-quality HD return feeds and bidirectional audio intercom.

VIDEO

Standards

HD: 1080p25/29.97/30/50/59.94/60,
1080i50/59.94/60,
720p50/59.94/60

SD: PAL, NTSC

Encoding

H.265/HEVC 4:2:0, 8-bit
H.264/AVC 4:2:0, 8-bit
Dynamic resolution adjustment

Bitrates

200 Kbps to 20 Mbps
Constant Bitrate (CBR)
Variable Bitrate (VBR)

Inputs

SDI, HDMI

AUDIO

Encoding

AAC-LC

Bitrates

32 Kbps to 256 Kbps

Mode

Mono, Dual Mono or Stereo 2.0

Density

Up to 4 channels

Inputs

Embedded (SDI, HDMI), Analog (L/R)

NETWORK CONNECTIONS

Cellular

2 x 5G/4G/3G or 2 x 4G/3G worldwide compliant modems with high gain custom antennas (sub-6 GHz).

Extensible with external modems (2 x USB ports).

Ethernet

Gigabit Ethernet port
- LAN, WAN
- Portable satellite (BGAN, Ka and Ku Band)

Wi-Fi

Dual band Wi-Fi modem 802.11b/g/n/ac (MIMO 2.4 GHz and 5 GHz)
- Client & Hot Spot modes
- High-efficiency embedded antenna

Transport Protocols

SST over Cellular/Ethernet/Wi-Fi (bonding)
SRT over Ethernet (caller and listener modes)

ADVANCE FEATURES

Dual encoding for simultaneous Live & Record
Sub second glass-to-glass latency (down to 500 ms)
Video and Audio level preview
Intercom /IFB
Video return from Studio (full HD, sub-second latency)
Automatic Live Start
Network links priorities (user configurable)
Data Bridge for switching the device as a mobile router
Hot folder mode for enabling smart and automatic files Forward
AES scrambling
Geolocation (GPS and Galileo)

INTERFACES

1 x 3G-SDI input (BNC), 1 x 3G-SDI output (BNC)
1 x HDMI 1.4 input, 1 x HDMI 1.4 output
1 x RJ-45 Ethernet
2 x USB 3.0 (type-A)
1 x 3.5 mm audio jack (for IFB / intercom headset)
2 x mini XLR balanced (for analog audio)
1 x SD card slot
4 x micro SIM slots

CONTROL & MONITORING

On screen display
Web GUI (through laptop, smartphone, etc.)
from Haivision Manager Management System
from Haivision Streamhub Transceiver

POWER

Power Supply

Internal 48Wh battery (up to 3 hours)
DC input 19V

PHYSICAL

Dimensions (W x H x D)

15.8 cm x 6.6 cm x 12.0 cm
(6.22" x 2.36" x 4.72")

Weight

AIR3: 1.21 Kg / 2.67 lbs (w/ battery)
0.97 Kg / 2.14 lbs (w/o battery)
AIR2: 1.08 Kg / 2.38 lbs (w/ battery)
0.85 Kg / 1.87 lbs (w/o battery)

Operation Temperature

0°C to 45°C (32°F to 113°F)

System Overview

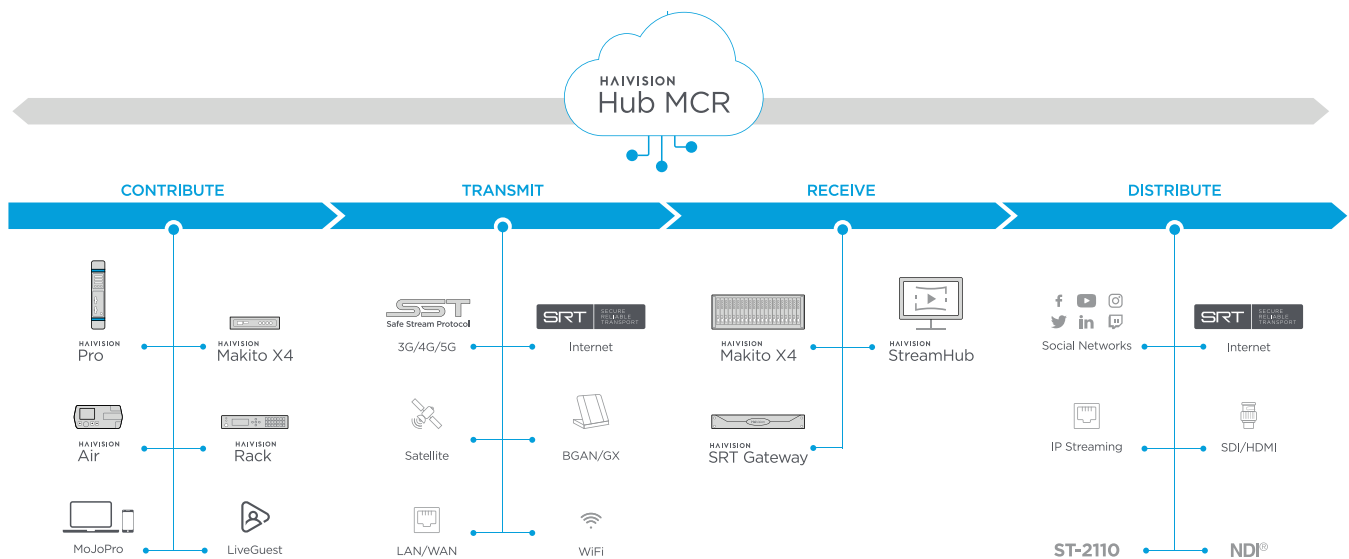



Encode Low Latency Video Up to 4K

Real-time encoding for mission-critical video.

4K UHD Video Encoding Makito FX Encoder is a compact, fanless, and robust video appliance that can encode HDMI or 12G-SDI sources to H.264/AVC and H.265/HEVC. Designed for real-time video distribution over secure networks, the Makito FX features a powerful low-latency encoding engine that supports resolutions up to 4K UHD at up to 60 frames per second, along with 4 channels of digital audio. Easily manage advanced video encoding and streaming settings through a secure browser-based user interface by connecting it to an IP network.

Secure and Reliable Streaming The Makito FX Encoder has been designed to meet the video network security requirements of mission-critical environments. It can be deployed to remote locations to encode and stream live video and computer graphics to command centers at very low latency, enabling real-time analysis and quick decision-making. The Makito FX can also be relied upon for secure streaming of control room displays and common operating pictures to off-site decision makers.

The Makito FX features a hardened operating system, dual network interfaces, and support for IPv6. The two ethernet ports enable operators to keep device management and control separate from a video streaming network or enable hitless failover over two networks. As with all Haivision Makito encoders, the Makito FX natively supports the SRT protocol for reliable and secure video streaming with AES encryption.

FEATURES

BENEFITS

Ultra-Low Latency

Extremely low latency encoding and video streaming for sharing real-time mission-critical imagery over a secure IP network.

4K UHD Video Encoding

Efficient real-time HEVC/H.264 video encoding up to 3840x2160p60 from an HDMI or 12G-SDI source.

Dual Network Interfaces

Ensure live content streaming with path redundancy or keep device management separate from video network.

SRT Support for Secure and Reliable Transport

Receive live streams without packet loss and protect valuable video content by ensuring it is viewed by intended audiences only.

INPUT VIDEO INTERFACES

- HDMI 2.1
- 1 full size BNC
- SD-SDI SMPTE 259M-C
- HD-SDI SMPTE 292M
- SMPTE 274M
- SMPTE 296M
- 3G-SDI SMPTE 424M (Level A only)
- SMPTE 425M
- 6G-SDI SMPTE 2081
- 12G-SDI SMPTE 2082

INPUT VIDEO RESOLUTIONS

- 3840x2160p60/59.94/50/30/29.97/25/24/23.98 HZ
- 1920x1080p60/59.94/50/30/29.97/25/24/23.98 HZ
- 1920x1080i60/59.94/50 HZ
- 1280x720p60/59.94/50/30/29.97/25 HZ
- 576i50
- 480i29.97/30
- (interlaced from HEVC only, shown in fields per second)

VIDEO ENCODING

- 8-bit or 10-bit pixel depth
- Chroma sub-sampling 4:2:0 or 4:2:2
- BT.709 color space and WCG (BT.2020)
- SDR and HDR - HLG or PQ (ST 2084)
- I, IP, IBP, IBBP, IBBBP, IBBBBP framing
- Configurable output frame rate
- Slice-based encoding
- H.264/AVC Profiles:
 - MPEG-4 AVC part 10 / ISO/IEC 14496-10
 - Baseline, Main and High Profiles up to Level 5.2
- H.265/HEVC Profiles:
 - ISO/IEC 23008-2
 - Baseline, Main and High Profiles up to Level 5.1

INPUT AUDIO INTERFACES

- Embedded Audio:*
- SD-SDI SMPTE 272M
- HD/3G-SDI SMPTE 299M
- HDMI (1 stereo)

AUDIO ENCODING

- Compression Standard:*
- MPEG-2 AAC LC ISO/IEC 13818-7
- MPEG-4 AAC-LC ISO/IEC 14496-3
- Audio Channels:*
- Up to 4 stereo pairs
- Frequency Response:*
- From 20 Hz to 22 kHz

METADATA

- Input Metadata*
- CoT to KLV conversion
- KLV or CoT over UDP
- KLV over SDI
- SMPTE 336M compliant
- MISB 0601.10 compliant
- MISB 0604.2 compliant
- SMPTE ST 352 Payload ID (HDR)
- SMPTE 12M Timecode
- SMPTE 334-1/2 Closed Captioning
- Output Metadata*
- Asynchronous & synchronous modes
 - as per MISB 0604.2
 - High precision timecode insertion
 - as per MISB 0604.2
- KLV Metadata Processing (SMPTE 336M, MISB 0601, 0102 and 0605 support)

IP NETWORK INTERFACES

- Connectivity:*
- 2 x RJ45 port Ethernet 10/100/1000 Mbps
- Streaming Protocols:*
- MPEG-TS over UDP
- MPEG-TS over RTP
- Secure Reliable Transport (SRT)
- Unicast streaming IPv4/IPv6
- Multicast streaming (IGMPv3 & IPv6)
- Multiple unicast streaming
- Advanced Streaming Features:*
- AES encryption 128-bit or 256-bit
- SRT Latency Control
- Forward Error Correction (FEC)

MANAGEMENT INTERFACES

- IP/Ethernet (IPv4 and IPv6)
- Management:*
- HTTPS (web browser)
- REST API
- Command line over SSH/Telnet
- SFTP/TFTP/SCP
- SNMPv3

APPLIANCE

- Dimensions (without brackets):*
- 43.6mm H x 114mm W x 129.7mm D / 115mm D without connectors
- (1.72" H x 4.49" W x 5.11" D / 4.53" D without connectors)
- Weight:*
- 585 g (1.29 lbs)
- Power:*
- 12 VDC nominal, 14.5W
- Temperature:*
- Operating: 0°C to 50°C (32°F to 122°F)
- Non-Operating: -30°C to 70°C (-22°F to 158°F)

Software version: 1.0

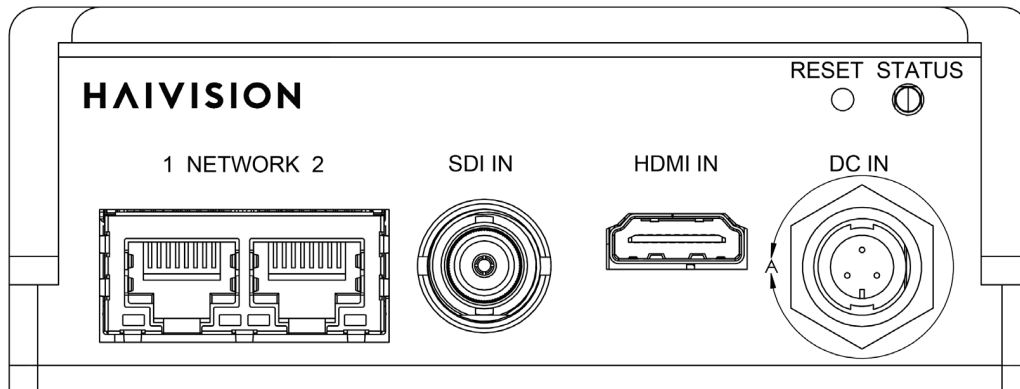

Makito FX Encoder

Makito FX Encoder Product Portfolio & Ordering Information **

Makito FX Encoder

S-MFXE-SDI-HDMI-ISR

Makito FX SDI+HDMI Encoder Appliance - H.264/AVC & H.265/HEVC IP Video/Graphic Encoder - Resolution up to 4K/UHDp60 with KLV Metadata

** For complete pricing and ordering, contact us at sales@haivision.com or your certified Haivision reseller.



4K UHD and HD Video Encoder for Low Latency, Broadcast Quality Streaming.

Secure, low latency, broadcast quality video encoders for live sports and news, real-time corporate communications, and mission critical defense applications.

Haivision Makito X4 is a highly versatile real-time HEVC/H.265 and AVC/H.264 video encoder available as a compact standalone appliance or as a rackmountable blade. Designed for the most demanding live video applications, the Makito X4 can encode up to four 1080p50/60 HD inputs or a full 2160p50/60 4K UHD video source with 10-bit pixel depth, 4:2:2 chroma subsampling, as well as up to 32 channels of digital audio. Robust and reliable, the Makito X4 offers 8 powerful encoding cores that can securely deliver simultaneous low latency multi-bitrate streams over any network, including the public internet.

4K Broadcast Quality Video Encode live video in HD or 4K UHD, up to 60 frames per second, with excellent picture quality even at low bitrates. For workflows where color precision is needed, the Makito X4 offers 4:2:2 chroma subsampling to ensure that color fidelity can be maintained, and artefacts prevented, in downstream workflows.

High Dynamic Range In addition to SDR, 10-bit pixel depths, and wide color gamut support (WCG), the Makito X4 can also encode live content for HDR workflows with HLG or PQ (ST 2084) transfer functions.

Ultra-Low Latency Streaming Up to 8 encoding cores can encode and stream HEVC and H.264 video with very low latency, which makes the Makito X4 ideally suited for interactive video applications such as field contribution, live interviews, return feed confidence monitoring as well as streaming synchronized camera feeds for remote productions.

High Density HEVC Encoding Processing video from multiple cameras is challenging when physical space is limited. The Makito X4 is a compact, easily portable appliance making it perfect to deploy in remote locations and on mobile platforms. When used in conjunction with Haivision rack-mountable enclosures, the Makito X4 offers the highest channel density available, giving facilities up to 84 HD or 21 UHD video sources within a single 4RU rack module.

Flexible and Future Proof With a powerful encoding engine built on top of a programmable platform, the Makito X4 video encoder addresses a wide range of live production applications today and tomorrow, including 4K, HDR and SMPTE ST 2110, ensuring that your production workflows address today's critical needs, and are flexible enough to adapt to your future infrastructure requirements.

Secure Content Encryption, Reliable Streaming The Makito X4 can encrypt video streams with up to 256-bit AES key lengths using the SRT protocol, which is critical when sharing valuable content over the internet. Moreover, to ensure reliable and continuous streaming, even when network conditions are unpredictable, the Makito X4 Encoder adapts to fluctuating network bandwidth in real-time, limiting packet loss and ensuring uninterrupted high-quality video.

FEATURES

BENEFITS

4K UHD Video

Efficient real-time HEVC/H.265 and H.264/AVC video encoding up to 3840x2160p 50/60 with 4:2:2 chroma subsampling and 10-bit pixel depth for impeccable picture quality for HDR workflows.

Ultra-Low Latency

Extremely low latency encoding and streaming enabling interactivity for live bi-directional interviews and field contribution.

High-Density Form Factor

4 inputs per appliance/blade, up to 84 inputs and 168 encoding cores per 4RU rack ideal for constrained spaces and high-density environments where Size, Weight and Power considerations are critical.

Flexible and Future Proof

The versatility of the Makito X4 enables future migration from HD to 4K, SDR to HDR, and SDI to SMPTE ST 2110 via its SFP+ port for dual NIC support.

Secure, Encrypted Video

Protect valuable video content with SRT and AES-128/256 encryption.

SRT Protocol for Reliable Streaming

Deliver live streams to decoders and cloud-based workflows without packet loss over fluctuating bandwidth networks including the internet.

VIDEO INTERFACES

(Quad mini-BNC Inputs)
 SD-SDI SMPTE 259M-C
 HD-SDI SMPTE 292M
 SMPTE 274M
 SMPTE 296M
 3G-SDI SMPTE 424M (Level A Only)
 SMPTE 425M
 6G-SDI SMPTE 2081 (1 input only)
 12G-SDI SMPTE 2082 (1 input only)
 SMPTE ST 2110 (with 10G SFP+ transceiver)

VIDEO RESOLUTIONS

3840x2160p 60/59.94/50 Hz *
 3840x2160p 30/29.97/25 Hz
 1920x1080p 60/59.94/50/30/29.97/25/24/23.98 Hz
 1920x1080i 60/59.94/50 Hz **
 1280x720p 60/59.94/50/30/29.97/25 Hz
 720x480/576i 60/59.94/50 Hz **

VIDEO ENCODING

8-bit or 10-bit pixel depth
 Chroma sub-sampling 4:2:0 or 4:2:2
 BT.709 color space and WCG (BT.2020)
 SDR and HDR - HLG or PQ (ST 2084)
 Configurable Group of Picture (GOP) size
 I, IP, IBBP, IBBBP, IBBBBP Framing
 Bitrates from 32 kbps to 120 Mbps***
 Configurable frame rate
 Intra-refresh
 Slice-based encoding

H.264/AVC Profiles:

MPEG-4 AVC part 10 / ISO/IEC 14496-10
 Baseline, Main, High, High 10-Bit and High 4:2:2
 10-Bit Profiles up to Level 5.2 (3840x2160p60)
 and lower intermediate levels

H.265/HEVC Profiles:

ISO/IEC 23008-2
 Main, Main 10-Bit, Main 4:2:2 10-Bit Profiles
 up to Level 5.1 (3840x2160p60) and lower
 intermediate levels

* SMPTE ST 2110 input up to 2160p30

** Interlaced video encoding shown in fields per second and supported in HEVC only

*** max bitrate depends on configuration

AUDIO INTERFACES

Embedded Audio:
 SD-SDI SMPTE 272M HD/3D-SDI SMPTE 299M
AUDIO ENCODING
Compression Standard:
 MPEG-2 AAC-LC ISO/IEC 13818-7
 MPEG-4 AAC-LC ISO/IEC 14496-3
Audio Channels:
 32 (16 stereo pairs) embedded (SDI) audio inputs
Bit Rates:
 From 14 to 576 kbps per audio pair
Frequency Response:
 From 20 Hz to 22 kHz

METADATA

Input Metadata:
 CoT to KLV conversion
 KLV or CoT over UDP
 KLV over SDI (SMPTE 336)
 SMPTE 336M compliant
 MISB 0601.10 compliant
 MISB 0604.2 compliant
 SMPTE ST 352 Payload ID (HDR)
 SMPTE 12M Timecode
 SMPTE 334-1/2 Closed Captioning
Output Metadata:
 Asynchronous & synchronous modes
 as per MISB 0604.2
 High precision timecode insertion
 as per MISB 0604.2
 KLV Metadata Processing (SMPTE 336,
 MISB 0601, 0102 and 0605 support)

IP NETWORK INTERFACES

Standard:
 Single Ethernet 10/100/1000
 Base-T, auto-detect, Half/Full-duplex
 Unicast streaming IPv4/IPv6
 Multicast streaming (IGMPv3 & IPv6)
 Multiple unicast streaming
 Path Redundancy – SRT across multiple networks
 SFP+ port - second NIC with MSA compliant
 1G/10G SFP+ transceiver
H.264 Streaming Protocols:
 MPEG Transport Stream
 Secure Reliable Transport (SRT)
 TS over SRT, UDP or RTP
 RTSP/RTMP
HEVC Streaming Protocols:
 MPEG Transport Stream
 Secure Reliable Transport (SRT)
 TS over SRT, UDP or RTP
 RTSP/RTMP

MANAGEMENT INTERFACES

IP/Ethernet (IPv4 and IPv6)
Management:
 HTTPS (web browser)
 Haivision EMS and Hub
 Command line over SSH/Telnet
 SFTP/TFTP/SCP
 SNMP v3

SIZE, WEIGHT, POWER

(single height appliance)
Dimensions:
 24mm H x 152mm W x 192mm D
 0.94" H x 5.98" W x 7.56" D
Weight:
 1.08 kg (2.37 lbs)
Power:
 12 VDC Nominal, 18W
Temperature:
 Operating: 0° to 40°C (32° to 104°F)
 Non-operating: -30° to 70°C (-22° to 158°F)
 Humidity: 0-95% non-condensing

Compatible with Haivision MB6x and MB21x multi-blade chassis.

Software Version: 1.4

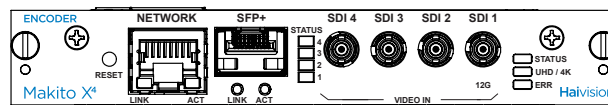
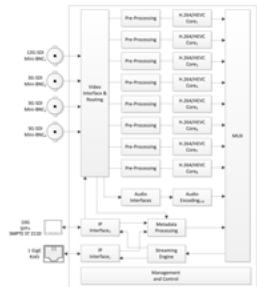

Makito X4 Encoder

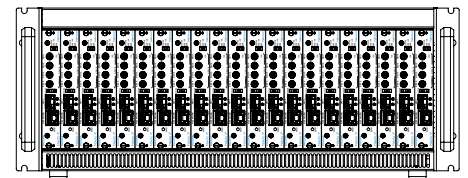

Compatible with Haivision MB21x multi-blade chassis

Makito X4 Product Portfolio & Ordering Information **

| | | |
|--------------------------------|------------------------|---|
| Makito X4 Blade - HD | B-MX4E-SDI4 | Makito X4 SDI Encoder Blade - H.264/AVC & H.265/HEVC IP Video Encoder - Quad channel 3G/HD/SD-SDI |
| Makito X4 Appliance - HD | S-MX4E-SDI4 | Makito X4 SDI Encoder Appliance - H.264/AVC & H.265/HEVC IP Video Encoder - Quad channel 3G/HD/SD-SDI |
| Makito X4 Blade - UHD | B-MX4E-SDI4-UHD | Makito X4 SDI Encoder Blade - H.264/AVC & H.265/HEVC IP Video Encoder up to 4K UHD |
| Makito X4 Appliance - UHD | S-MX4E-SDI4-UHD | Makito X4 SDI Encoder Appliance - H.264/AVC & H.265/HEVC IP Video Encoder SDI up to 4K UHD |
| Makito X4 KLV and CoT Metadata | SWO-MX4-KLVCOT | Software license option - Support KLV and CoT metadata |
| Makito X4 UHD - upgrade | SWO-MX4-UHD | Software license option - Upgrade from HD to 4K UHD |
| HDR License | SWO-MX4-HDR | Software license option - Support HLG and PQ (ST 2084) transfer function |
| ST 2110 License | SWO-MX4-2110 | Software license option - Enable SMPTE ST 2110 input with MSA compliant 10G SFP+ transceiver |

** For complete pricing and ordering, contact us at sales@haivision.com or your certified Haivision reseller.



4K UHD/HD Video Encoder for Low Latency, Broadcast Quality Streaming

Secure, low latency, broadcast quality video encoders for live sports and news, real-time corporate communications, and mission critical defense applications.

Haivision Makito X4 is available as a single-channel HD/UHD video encoder and can be deployed as a compact standalone appliance or as a rack mountable blade. Designed for the most demanding live video applications, the single-channel Makito X4 can encode 4K, HD, and SD at up to full 2160p50/60 4K UHD or 1080p50/60 HD video sources with 10-bit pixel depth, 4:2:2 chroma subsampling, as well as up to 8 channels of digital audio in HEVC or H.264.

Broadcast Quality Video Up to 4K Leveraging 12G-SDI, 3G-SDI or even ST 2110 sources, encode 4K UHD and HD live video at up to 60 frames per second, with excellent picture quality even at low bitrates. For workflows where color precision is needed, the Makito X4 offers 4:2:2 chroma subsampling to ensure that color fidelity can be maintained, and artefacts prevented, in downstream workflows.

High Dynamic Range In addition to SDR, 10-bit pixel depths, and wide color gamut support (WCG), the Makito X4 can also encode live content for HDR workflows with HLG or PQ (ST 2084) transfer functions.

Ultra-Low Latency Streaming Encode and stream HEVC and H.264 with very low latency, which makes the Makito X4 ideally suited for live broadcast video applications such as field contribution, live interviews, return feed confidence monitoring as well as streaming synchronized camera feeds for remote productions.

High Density 4K HEVC Encoding Processing video from multiple cameras is challenging when physical space is limited. The Makito X4 is a compact, easily portable 4K-capable appliance making it perfect to deploy in remote locations and on mobile platforms. When used in conjunction with Haivision rack-mountable enclosures, the Makito X4 offers the highest 4K channel density available, giving facilities up to 21 UHD video sources within a single 4RU rack module.

Flexible and Future Proof The Makito X4 video encoder addresses a wide range of live production applications today and tomorrow, including 4K, HDR and SMPTE ST 2110, ensuring that your production workflows address today's critical needs, and are flexible enough to adapt to your future infrastructure requirements.

Secure Content, Reliable Streaming The Makito X4 can encrypt video streams with up to 256-bit AES key lengths using the SRT protocol, which is critical when sharing valuable content over the internet. Moreover, it features a secure operating system, dual network interfaces to separate streaming from management, and support for IPv6. Built with reliability at the core, the Makito X4 provides uninterrupted streaming, even when network conditions are unpredictable.

FEATURES

BENEFITS

4K UHD video

Efficient real-time HEVC/H.265 and H.264/AVC video encoding up to 3840x2160p 50/60 with 4:2:2 chroma subsampling and 10-bit pixel depth for impeccable picture quality for HDR workflows.

Ultra-low latency

Extremely low latency encoding and streaming enabling interactivity for live bi-directional interviews and field contribution.

High-density 4K form factor

4 inputs per appliance/blade, up to 21 inputs per 4RU rack ideal for constrained spaces and high-density environments where Size, Weight and Power considerations are critical.

Flexible and future proof

The versatility of the Makito X4 enables migration from HD to 4K, SDR to HDR, and SDI to SMPTE ST 2110.

Secure, encrypted video

Protect valuable video content with SRT and AES-128/256 encryption, a secure operating system, dual network interfaces, and support for IPv6.

SRT protocol for reliable transport

Deliver live streams to decoders and cloud-based workflows without packet loss over unpredictable networks including the internet.

VIDEO INTERFACES

(Standard Single BNC Input)
 SD-SDI SMPTE 259M-C
 HD-SDI SMPTE 292M
 SMPTE 274M
 SMPTE 296M
 3G-SDI SMPTE 424M (Level A Only)
 SMPTE 425M
 6G-SDI SMPTE 2081 (1 input only)
 12G-SDI SMPTE 2082 (1 input only)
 SMPTE ST 2110 (with 10G SFP+ transceiver)

VIDEO RESOLUTIONS

3840x2160p 60/59.94/50 Hz *
 3840x2160p 30/29.97/25 Hz
 1920x1080p 60/59.94/50/30/29.97/25/24/23.98 Hz
 1920x1080i 60/59.94/50 Hz **
 1280x720p 60/59.94/50/30/29.97/25 Hz
 720x480/576i 60/59.94/50 Hz **

VIDEO ENCODING

8-bit or 10-bit pixel depth
 Chroma sub-sampling 4:2:0 or 4:2:2
 BT.709 color space and WCG (BT.2020)
 SDR and HDR - HLG or PQ (ST 2084)
 Configurable Group of Picture (GOP) size
 I, IP, IBBP, IBBBP, IBBBBP Framing
 Bitrates from 32 kbps to 120 Mbps***
 Configurable frame rate
 Intra-refresh
 Slice-based encoding

H.264/AVC Profiles:

MPEG-4 AVC part 10 / ISO/IEC 14496-10
 Baseline, Main, High, High 10-Bit and High 4:2:2
 10-Bit Profiles up to Level 5.2 (3840x2160p60)
 and lower intermediate levels

H.265/HEVC Profiles:

ISO/IEC 23008-2
 Main, Main 10-Bit, Main 4:2:2 10-Bit Profiles
 up to Level 5.1 (3840x2160p60) and lower
 intermediate levels

AUDIO INTERFACES

Embedded Audio:
 SD-SDI SMPTE 272M HD/3D-SDI SMPTE 299M
 AUDIO ENCODING
Compression Standard:
 MPEG-2 AAC-LC ISO/IEC 13818-7
 MPEG-4 AAC-LC ISO/IEC 14496-3
Audio Channels:
 8 (4 stereo pairs) embedded audio inputs
Bit Rates:
 From 14 to 576 kbps per audio pair
Frequency Response:
 From 20 Hz to 22 kHz

METADATA

Input Metadata:
 CoT to KLV conversion
 KLV or CoT over UDP
 KLV over SDI (SMPTE 336)
 SMPTE 336M compliant
 MISB 0601.10 compliant
 MISB 0604.2 compliant
 SMPTE ST 352 payload ID (HDR)
 SMPTE 12M timecode
 SMPTE 334-1/2 closed captioning
 SCTE 104 insertion markers
Output Metadata:
 Asynchronous & synchronous modes
 as per MISB 0604.2
 High precision timecode insertion
 as per MISB 0604.2
 KLV Metadata Processing (SMPTE 336,
 MISB 0601, 0102 and 0605 support)
 SCTE 35 insertion markers

IP NETWORK INTERFACES

Standard:
 Single Ethernet 10/100/1000
 Base-T, auto-detect, Half/Full-duplex
 Unicast streaming IPv4/IPv6
 Multicast streaming (IGMPv3 & IPv6)
 Multiple unicast streaming
 Path Redundancy – SRT across multiple networks
 SFP+ port - second NIC with MSA compliant
 1G/10G SFP+ transceiver
H.264 Streaming Protocols:
 MPEG Transport Stream
 Secure Reliable Transport (SRT)
 TS over SRT, UDP or RTP
 RTSP/RTMP
HEVC Streaming Protocols:
 MPEG Transport Stream
 Secure Reliable Transport (SRT)
 TS over SRT, UDP or RTP
 RTSP/RTMP

MANAGEMENT INTERFACES

IP/Ethernet (IPv4 and IPv6)
Management:
 HTTPS (web browser)
 Haivision EMS and Hub
 Command line over SSH/Telnet
 SFTP/FTPT/SCP
 SNMP v3

SIZE, WEIGHT, POWER

(single height appliance)
Dimensions:
 24mm H x 152mm W x 192mm D
 0.94" H x 5.98" W x 7.56" D
Weight:
 1.08 kg (2.37 lbs)
Power:
 12 VDC Nominal, 18W
Temperature:
 Operating: 0° to 40°C (32° to 104°F)
 Non-operating: -30° to 70°C (-22° to 158°F)
 Humidity: 0-95% non-condensing

Compatible with Haivision MB6x and MB21x multi-blade chassis.

* SMPTE ST 2110 input up to 2160p30

** Interlaced video encoding shown in fields per second and supported in HEVC only

*** max bitrate depends on configuration

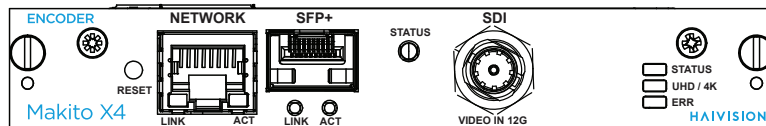

Makito X4 Single-Channel Encoder

Makito X4 Single-Channel Encoder Product Portfolio & Ordering **

| | | |
|--|------------------------|--|
| Makito X4 Single Encoder Blade - UHD | B-MX4E-SDI1-UHD | Makito X4 SDI Encoder Blade - H.264/AVC & H.265/HEVC IP Video Encoder - Single channel 12G/3G/HD/SD-SDI with UHD & ST 2110 |
| Makito X4 Single Encoder Appliance - UHD | S-MX4E-SDI1-UHD | Makito X4 SDI Encoder Appliance - H.264/AVC & H.265/HEVC IP Video Encoder - Single channel 12G/3G/HD/SD-SDI with UHD & ST 2110 |
| Makito X4 KLV and CoT Metadata | SWO-MX4-KLVCOT | Support KLV and CoT metadata - software license |
| Makito X4 HDR License | SWO-MX4-HDR | Support HLG and PQ (ST 2084) transfer function - software license |

** For complete pricing and ordering, contact us at sales@haivision.com or your certified Haivision reseller.

DoDIN APL Certified:

Makito X4 Encoder is on the Department of Defense Information Network Approved Product List (DODIN APL) under tracking number 2118301.



4K UHD & Multi-HD Encoder

The Haivision Rack400 is a compact video encoder for multi-camera HD, 4K UHD, and HDR remote production of live sports and news. The Rack400 includes hardware accelerated H.265/HEVC and H.264/AVC encoding for premium video quality with optimized bandwidth usage and end-to-end latency as low as 200ms.

For multi-camera broadcast contribution, up to four HD encodes, the Rack400 supports video and audio stream synchronization for seamless camera switching at production. The Rack400 can also connect to PTZ cameras and tally lights for remote control by a Haivision StreamHub receiver, even during live transmissions. To facilitate communications between field operators and production staff, the Rack400 offers video return feeds and a bidirectional audio intercom (IFB).

Designed for both fixed and mobile deployments, the Rack400 can be used as a standalone appliance or up to 2 units can be rackmounted in a 1RU space making it ideally suited for installation in OB vans. Rack400 encoders can be directly connected over wired IP networks, to mobile networks using the Haivision Quad CellLink active cellular antennas, or Ka satellite transmitters, enabling live video broadcasting from anywhere.



Simple

The Rack400 is extremely user-friendly and features an intuitive touch-screen user interface enabling camera operators to begin broadcasting live video with just 2 taps.



Versatile

The Rack400 is a versatile all-in-one solution for mobile video contribution and remote production. Encode and transmit a single 4K UHD source or four simultaneous HD sources with up to 10-bit pixel depths, 4:2:2 chroma subsampling, and in HDR.



High Performance

By implementing an ultra-low latency H.265/HEVC hardware encoder in a compact design enclosure, the Rack400 enables video professionals to provide seamless and pristine video for news and events coverage.



Any Network

Leveraging the Emmy® award winning SST and SRT protocols, the Rack400 can reliably transmit high-quality broadcast contribution video over any network even with fluctuating conditions.

Main Functions

Premium Live Video up to 4K UHD The Haivision Rack400 offers the highest-quality video performance and the latest generation of HEVC encoding technology for pristine HD and UHD video transmission over all types of IP networks. Supporting SRT for safe and reliable streaming over the internet as well as SST for cellular bonding technology using an optional Haivision Quad CellLink antenna, the Rack400 can transmit live video with bitrates up to 80Mbps for high-quality broadcast contribution.

Multi-camera Remote Production Bring your remote production and REMI workflows to the next level with four frame-synced HD feeds and simultaneous remote control of IP-based equipment including PTZ cameras. Thanks to high bandwidth and low-latency IP video transmission, the Rack400 enables multi-camera remote production from anywhere.

IFB & Video Return Ensure two-way audio communication between the producer, camera operator & on-air talent thanks to a seamless and robust intercom system. The Rack400 can also receive a high-quality and encrypted HD feed from the production studio during a live broadcast or in standby mode. With sub-second latency streaming, Rack400 return feeds can be used for watching on-air programs, teleprompting information or confidence monitoring from the field.

Record & Progressive Forward Record UHD/HD broadcast-grade quality video on an SD card, and optimize your file forwarding time by with progressive uploads while the live recording is still in progress. The Rack400's advanced recording and file forwarding enables fast and error-free video delivery over any IP network.

VIDEO

Standards

UHD: 2160p60/59.94/50/30/29.97/25
 HD: 1080p60/59.94/50/30/29.97/25
 1080i60/59.94/50
 720p60/59.94/50

Density

Single UHD/HD
 Quadruple HD

Encoding

H.265/HEVC 4:2:0/4:2:2, 8/10-bit
 H.264/AVC 4:2:0, 8-bit
 Dynamic resolution adjustment
 High Dynamic Range (HLG & PQ)

Bitrates

2 Mbps to 80 Mbps for UHD
 300 Kbps to 20 Mbps for HD
 Constant Bitrate (CBR)
 Variable Bitrate (VBR)

Inputs

SDI

AUDIO

Encoding

AAC-LC

Bitrates

32 Kbps to 256 Kbps

Mode

Mono, Stereo

Density

Up to 4 Mono or up to 4 Stereo

Inputs

Embedded over SDI

NETWORK CONNECTIONS

Ethernet

2 x Gigabit Ethernet ports
 - LAN, WAN
 - portable satellite (Ka & Ku Band)

Cellular

With optional Haivision Quad CellLink
 - 4 x 3G/4G-LTE world-wide compliant modems
 - 4 SIM slots
 - High efficiency embedded antenna

Transport Protocol

SST over Cellular/Ethernet (bonding)
 SRT over Ethernet

ADVANCED FEATURES

Dual encoding for simultaneous Live & Record (single HD mode)
 Sub second glass-to-glass latency (down to 200 ms in single encoder mode and down to 500 ms in multi-encoder mode)
 Video and Audio level preview
 Intercom/IFB with AES encryption
 Video return from studio (full HD, sub-second latency, AES encryption)
 Automatic Live Start
 Networks Links priorities (user configurable)
 Data Bridge for switching the device as mobile router
 Simultaneous Live and IP traffic (for remote camera control)
 SMPTE-12M timecode passthrough

INTERFACES

1 x 12G/3G-SDI input and 3 x 3G-SDI inputs (BNC)
 1 x 12G-SDI output (BNC)
 1 x HDMI 1.4 output
 1 x GenLock input (BNC)
 2 x RJ-45 Ethernet
 2 x USB 3.0 (type-A), 1 x USB 3.0 (type-C)
 1 x mini jack for IFB/intercom headset
 1 x micro SD card slot

CONTROL & MONITORING

Embedded touch screen
 Web UI (through laptop, smartphone, etc.)
 From Haivision StreamHub transceiver
 From Haivision Manager

POWER

Power Supply

Dual DC input 18V

Consumption

34W max (25W to 30W typical)

PHYSICAL

Dimensions (W x H x D)

22.2 cm x 4.4 cm x 11.5 cm
 (8.66" x 1.57" x 4.33")

Weight

1.36 Kg / 3.00 lbs

Operating Temperature

0°C to 40°C (32°F to 104°F)

System Overview

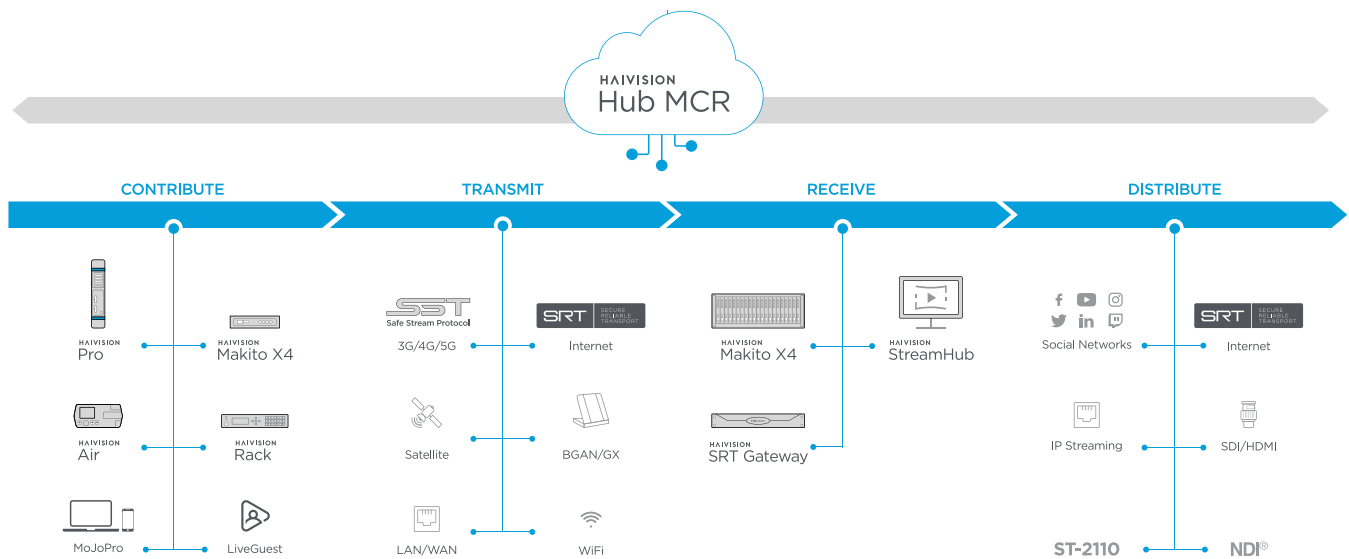



Versatile and easy-to-use mobile app for video professionals

The MoJoPro mobile app is designed for professional broadcasters, such as journalists or live video production agencies. The user-friendly and intuitive interface allows for broadcasting live video with a single screen tap. With its advanced camera settings, reliable video streaming and recording capabilities, and on-screen access to return feeds, MoJoPro is the ideal solution for quickly covering breaking news, conducting live interviews, and efficiently producing professional video content wherever you are, whenever you want.

Leveraging the Haivision SST protocol, an intelligent IP bonding stack for broadcast contribution, MoJoPro ensures the delivery of live video even when streaming over unpredictable networks. The application bonds the smartphone's internal WiFi and 5G/4G cellular connections for superior video quality and resilience. An external MiFi module can also be used, allowing two cellular connections to be linked in one smartphone.

Available on the Apple Store and Google Play, the MoJoPro app can be installed to run on a wide range of smartphones and tablets.



Simple

MoJoPro has been designed with ease-of-use in mind, the user-friendly intuitive interface allows broadcasting live videos in a single screen tap.



Any Device

MoJoPro runs on a wide range of smartphone and tablet models. The application is available on the Apple Store and Google Play.



Versatile

MoJoPro is the perfect flexible and agile solution to quickly cover breaking news, conduct interviews, and efficiently produce professional live videos.



Any Network

Leveraging Haivision's SST protocol, an intelligent IP bonding stack and powerful contribution network protocols, MoJoPro ensures the delivery of live video even in the midst of unpredictable and unmanaged network conditions.

Main Functions

Reliable Live Streaming Incorporate best-in-class video encoding technology to ensure high quality video even at low bitrates. Capture video from built-in front, rear, wide, and telephoto cameras along with audio from a wired or Bluetooth microphone.

Store and Forward Record video files, including during a live broadcast, which can be locally stored and edited before being forwarded on to a production destination.

Superior Camera Settings Support auto focus/manual focus, white balance, ISO, shutter speed, grid, and video resolution in an attractive GUI.

Video Return and IFB Ensure communication between the producer, camera operator & on-air talent with high-quality HD return feeds and bidirectional audio intercom (wired or Bluetooth headset).

VIDEO

Resolutions

- 3840 x 2160 (recording only from iOS 16) **
- 1920 x 1080
- 1280 x 720
- 640 x 480
- 640 x 360*

Frame rates

- 25/30fps
- 50/60fps*
- 29.97/59.94fps**

Encoding

- H.264/AVC 4:2:0, 8-bit
- H.265/HEVC 4:2:0, 8-bit
- Live: Dynamic and static resolutions
- Recording: Static resolution

Bitrates

- Up to 10 Mbps
- Constant Bitrate (CBR)
- Variable Bitrate (VBR)

Latency

- Configurable from 1.2 to 10 seconds

Inputs

- Built-in cameras (front, back, dual back, telephoto, ultra-wide)
- External camera with SDI/HDMI to USB-C adapter for Android smartphones

AUDIO

Encoding

- AAC-LC
- 32 kbps, 64 kbps, 128 kbps or 256 kbps
- Mono / Stereo

Inputs

- Built-in & external microphone (wired/Bluetooth)

NETWORK CONNECTIONS

- Cellular: 5G/4G/3G (depending on device and operator)
- WiFi
- Ethernet (with an adaptor)
- BGAN satellite (with a WiFi or Ethernet terminal)**

* not available on all Android devices

** only with iOS

ADVANCED FEATURES

- Live with/without simultaneous record
- Record with pause/resume function
- Still pictures during live or record
- IFB/Intercom with the studio
- Video return display (full screen or picture in picture)
- File forwarding with video preview
- Cellular and WiFi network aggregation with SST
- Microphone auto-selection (internal, wired and Bluetooth)
- Audio-Vu meter with gain adjustment
- Grid, horizontal, and vertical tilts
- Local metadata insertion for recorded clip**
- Story centric workflow with Studio metadata association to Live or forwarded clips
- Video editing**
 - Video clip sequencing
 - Video clip trimming
 - Logo overlay
 - Audio track /voice-over

CAMERA SETTINGS

- Portrait / Landscape / Auto
- Stabilization
- White Balance
- ISO
- Shutter Speed
- Focus
- Light

STREAM DESTINATIONS

- Haivision StreamHub receiver and decoder for delivery to SDI, NDI, SRT, HLS, MPEG-2 TS, RTSP or RTMP (Social Media outlets) workflows

PLATFORM

iPhone (iOS 12 to 16)

- 8, 8 Plus
- X, XS, XR, Xs Max
- 11, 11 Pro, 11 Pro Max
- 12, 12 Pro, 12 Pro Max
- 13, 13 Pro, 13 Pro Max
- SE

iPad

MacBook (with M1 & M2 chipsets)

Android devices (Android 8 to 13)

- Samsung S9, S10, S20
- Samsung A10, A20
- Huawei P20, P30
- LG G5
- Oppo Reno
- Xiaomi Mi 10
- OnePlus
- Google Pixel 4a (5G)

System Overview

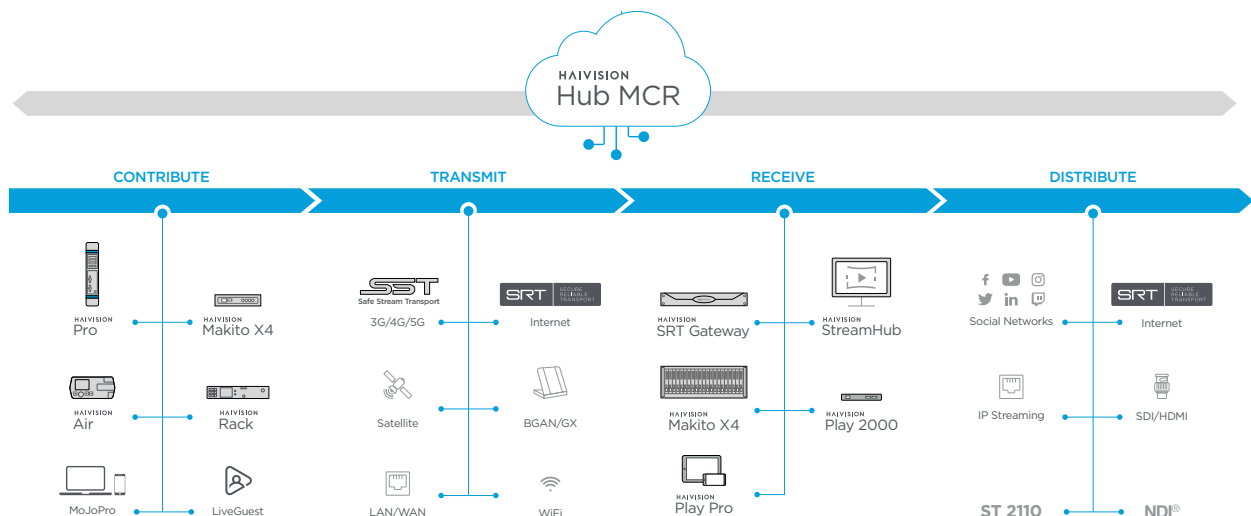

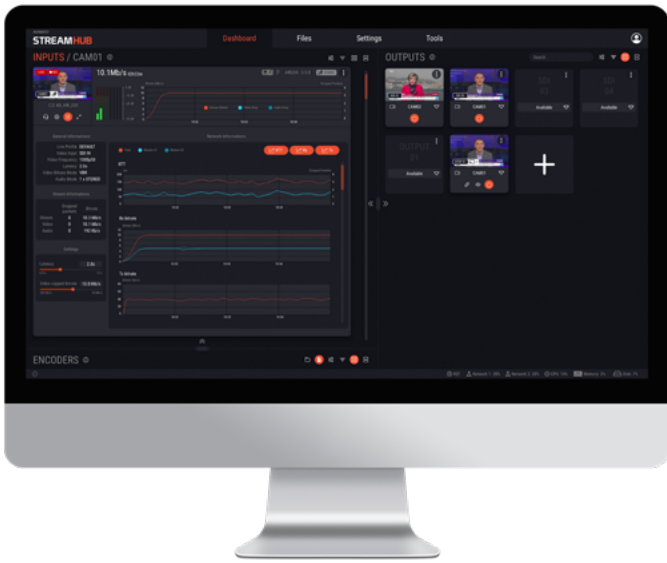

Versatile Broadcast Contribution Receiver and Decoder Solution

Haivision StreamHub is a versatile solution for receiving IP video streams over mobile networks and the internet. StreamHub can receive and decode live video from Haivision Pro and Air mobile transmitters, and Haivision Rack encoders using the two-time Emmy award winning SST technology for network aggregation. StreamHub can also receive live streams from the Haivision MoJoPro mobile application, LiveGuest browsed-based interviews, and SRT streams from Haivision encoders as well as from third party sources. Its intuitive web user interface enables users to easily control and manage remote field units, optimize configurations, and monitor video transmissions with video thumbnails and advanced statistics.

StreamHub has been designed to meet the demanding requirements of broadcasters deploying video contribution systems over mobile and IP networks. Supporting both H.264 and HEVC with resolutions up to 4K UHD, StreamHub can be deployed on-premise or in the cloud for low latency transcoding and decoding to SDI, NDI, ST-2110, SRT and other IP outputs.

Key Features

Mobile Video Receiver and Decoder StreamHub supports a rich set of IP protocols and can receive up to 16 concurrent incoming SST streams from remote Haivision mobile encoders and transmitters or third party sources through RTMP, RTSP/RTP, SRT, NDI, HLS, TS/IP streaming protocols. Up to 8 videos can be simultaneously decoded to 8 SDI outputs with genlock for multi-camera synchronization. StreamHub also features video transcoding capabilities for adapting incoming feeds to desired output formats.

IP Distribution StreamHub supports multiple streaming protocols including SST, RTMP, RTMPS, RTSP/RTP, HLS, TS/IP, SRT, and NDI so that video content can be easily distributed over IP networks for all types of destinations. Up to 32 outputs are supported, included duplicate streams, for sharing live content over LANs, WANs, CDNs, cloud platforms, Social Networks, and to other StreamHub receivers.

Video Recording And File-based Transcoding StreamHub combines video recording functions with a file-based video transcoder that enables media professionals to adapt content formats and resolutions for each destination.

Story Centric Workflows & Metadata StreamHub can be used to manually or automatically manage projects & metadata for smooth integration with news production workflows. Using the highly intuitive user interface, broadcasters and media producers can quickly and easily identify recorded content and live sources.

IP Data Bridge The StreamHub DataBridge feature provides direct access to the Internet from a field unit. Optimized for remote production workflows, it also allows for remote control of IP based devices such as PTZ cameras.

IFB and Video Returns StreamHub includes a two-way IFB or audio intercom that enables broadcasters to communicate in real-time with up to 16 remote field unit operators. StreamHub can also manage video returns for providing remote operators with studio feeds, confidence monitoring, and teleprompters.

Multiviewer Monitoring The grid view includes preview thumbnails of video sources that can be assigned to a multiviewer output displaying up to 16 video sources on a single monitor. Broadcast professionals can define audio sources, output standards, and add information overlays for each source.

PLATFORM

Physical

1 RU server platform

Software

Linux 64-bit server

Virtualized

Available as a Virtual Machine or Docker Instance
Running on AWS, Google Cloud, or any public/private cloud

VIDEO

Resolutions

4K/UHD: 25/29.97/30/50/59.94/60
HD: 1080p 25/29.97/30/50/59.94/60
1080i 50/59.94/60
720p 25/29.97/30/50/59.94/60
SD: PAL, NTSC, 480p, 576p

Decoding

Codec: H.264/AVC (4:2:0 8bits), H.265/HEVC (up to 4:2:2 10bits)
Bitrates: 100 kbps up to 160 Mbps
Regulation mode: VBR and CBR
Up to 8x HD or 1x 4K decoding (StreamHub Ultra)

Encoding

Codec: h.264/AVC 4:2:0 8bits
Bitrates: 100 kbps up to 20 Mbps
Regulation mode: CBR
Up to 8 HD live encoding (StreamHub Ultra)

Processing

Video Down-scaling & Upscaling
Deinterlacing

AUDIO

Decoding

AAC-LC, AAC-HE v2, MPEG-1 L2, OPUS

Encoding

AAC-LC, MPEG1-L2, OPUS

STREAMING PROTOCOLS

Inputs

TS/IP (SPTS), RTSP/RTP, RTMP push and pull,
HLS, SRT, IP Bonding (AVIWEST SST), NDI

Outputs

TS/IP (SPTS), RTSP/RTP, RTMP, RTMPS push and pull
HLS, SRT, IP Bonding (AVIWEST SST), NDI
SMPTE ST 2110 (up to 2 x 25Gbs)

ADVANCED FEATURES

Metadata support for Live and Forward
SIP-based and legacy intercom
AVIWEST SST protocol
IP Data Bridge Gateway
MPEG2-TS and MP4 recording
Transmuxing stream processing
Streaming to all major Social Media Platforms including Youtube, Facebook, and Twitch
Multi-view output
Video Return Management

PHYSICAL INTERFACES

StreamHub Lite

Dual GigE network interfaces
1x 3G-SDI or 1x HDMI output

StreamHub Standard

Dual GigE network interfaces
4 x 3G-SDI outputs (SD/HD) with genlock

StreamHub Ultra

Dual GigE network interfaces
Up to 8 x 3G-SDI outputs or 4 x 12G-SDI outputs with genlock

MONITORING

Web-based GUI
Comprehensive RESTfull API for third-party Management System integration
Integrated with AVIWEST MANAGER

POWER

Redundant power supply

System Overview

